



LIFT-A-LOFT

SP SERIES

SP SERIES

Lift-A-Loft's SP maintenance platform was developed from the most proven design in scissor mechanisms, hydraulic systems, and safety devices. The platform with Extenda-Deck (opt) is designed for overhead construction or maintenance. These units are drivable and steerable at all elevations allowing easy positioning and reduced setup time. Units meets all ANSI and OSHA standards fully complying with A92.6.

PERFORMANCE

- Travel Speed – Fully Proportional 0 – 2.2 mph (0 - 3.54 k/hr)
 - Travel Speed at Elevation – 0.7 mph (1.1 k/hr)
 - Inside Turning Radius: SPW – 5' 4" (1.62m) SPN – 0' 6" (0.15m)
 - Gradeability – 25%
 - Platform Lift Speed – 0.43 ft/sec (0.13 m/sec)
 - Platform Lower Speed – 0.54 ft/sec (0.16 m/sec)
- *Lift/Lower speed may vary according to load and atmospheric conditions

OPTIONAL EQUIPMENT

- Flashing or Rotating Warning Lights
- Extenda-deck Front or Side Platform Extension
- Air Powered Units
- All Motion Alarm
- Air Line to Platform
- Platform Mounted Work Lights
- Padded Rails
- Aircraft Bumpers
- Custom Paint
- Call LIFT-A-LOFT for Custom Designed Units

FEATURES

- 110VAC Circuit to Platform
- Standard Paint – Green with Yellow Guardrails
- Wheels – 16" X 4" (0.41 X 0.10m)
- Brakes – Spring Applied, Pressure Release

BATTERY INFORMATION

- (4) 6 Volt Deep Cycle 275 AH Batteries Provide 24 Volt System with On Board Fully Automatic

SAFETY FEATURES

- Scissor Spreader
- Self Closing, Self Latching Gate
- Guardrails with Midrail and Toe Board
- Emergency Stop Button at Each Control Station
- Manual Override Lowering at Ground Level
- Lanyard Attachment Points
- Non-skid Flooring on Foot Traffic Areas
- Deadman Controls
- Holding Valve(s) on Lift Cylinder(s)
- Horn

LIFT-A-LOFT SPECIALIZING IN CUSTOM SCISSOR LIFTS DESIGNED TO MEET A CUSTOMERS SPECIFIC APPLICATION NEEDS.



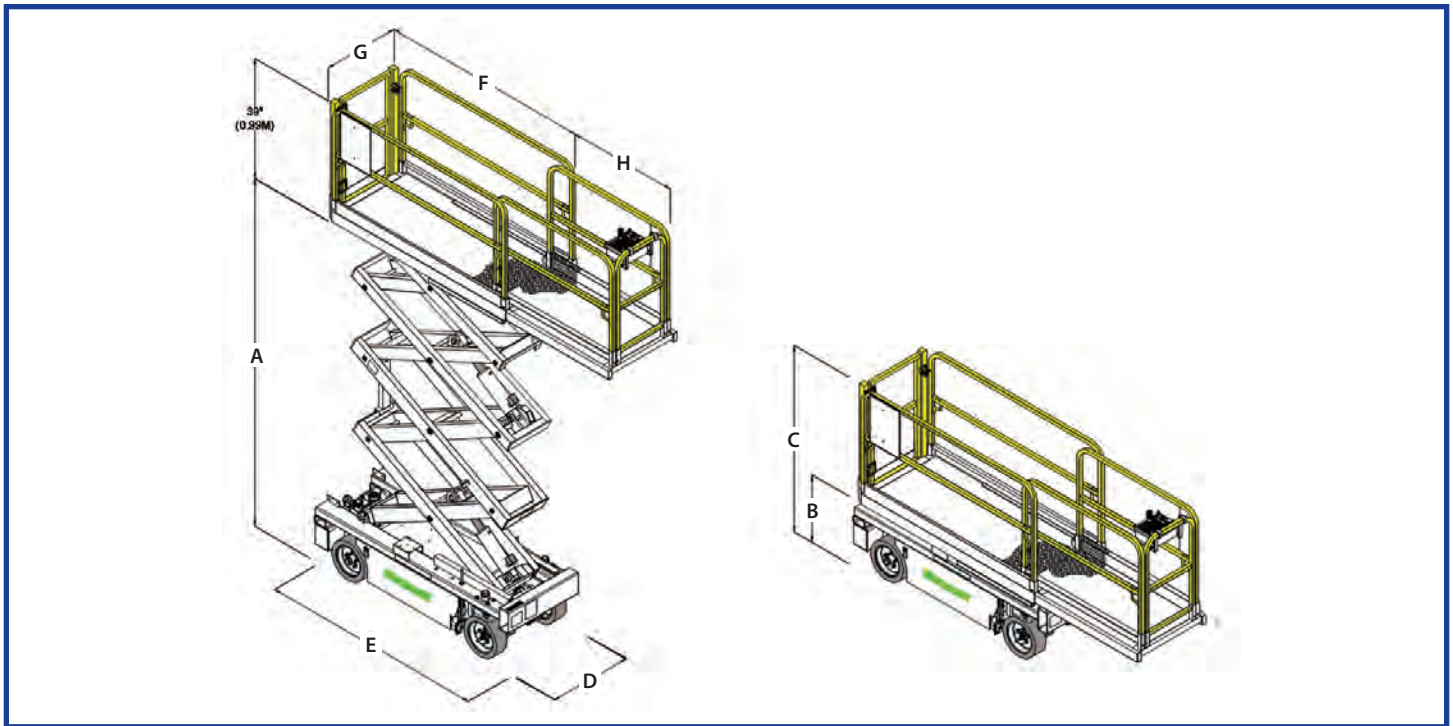

MODEL	A MAX .PLAT- FORM HT	B MIN. PLAT- FORM HT	C TRAVEL HT	D BASE WIDTH	E BASE LENGTH	F PLATFORM LENGTH	G PLATFORM WIDTH	PLATFORM CAPAC- ITY WITHOUT EAD	APPROX. SHIP- PING WT.
SPW24	23' 8" (7.21m)	44" (1.12m)	6' 11" (2.11m)	50" (1.26m)	87" (2.21m)	87" (2.21m)	46" (1.17m)	750 lbs (340.2kg)	4,940 lbs (2,240.7kg)
SPN20	19' 10" (6.04m)	43" (1.09m)	6' 10" (2.08m)	30" (0.76m)	81" (2.06m)	75" (1.91m)	30" (0.76m)	700 lbs (317.5kg)	4,380 lbs (1,986.7kg)
SPW19	19' 2" (5.84m)	39" (0.99m)	6' 6" (1.98m)	50" (1.26m)	87" (2.21m)	87" (2.21m)	46" (1.17m)	1,500 lbs (680.4kg)	4,160 lbs (1,886.9kg)
SPN16	15' 6" (4.72m)	38" (0.97m)	6' 7" (2.01)	30" (0.76m)	81" (2.06m)	75" (1.91m)	30" (0.76m)	800 lbs (362.9kg)	3,840 lbs (1,741.7kg)

OPTIONAL EXTENDA-DECK INFORMATION

MODEL	H EXTENDA - DECK SIZE	CAPACITY
SPW24 (87" Long Platform w/4' EAD)	4' (1.22m)	750lbs (340.2kg)
SPW19 (87" Long Platform w/4' EAD)	4' (1.22m)	1200lbs (544.3kg)
SPW 4' EAD	—	700lbs (317.5kg)
SPN 4' EAD	—	350lbs (158.8kg)

