



SUMMIT
TOYOTALIFT

visit us online at
summithandling.com

PRE-SHIFT INSPECTION

Date: _____ Time: _____

Operator: _____

Shift: _____ Truck #: _____

Narrow Aisle Truck Check List

Check NO where issues are detected

Visual Inspection	
NO	COMMENTS
1. <input type="checkbox"/>	Battery _____ Vent Caps _____ Connector Covers _____ Cables _____
2. <input type="checkbox"/>	Drive and Wheel Load _____
3. <input type="checkbox"/>	Overhead Guard _____
4. <input type="checkbox"/>	Tilt Cylinder _____
5. <input type="checkbox"/>	Carriage _____
6. <input type="checkbox"/>	Forks _____
7. <input type="checkbox"/>	Mast _____
8. <input type="checkbox"/>	Cylinder Lift _____ (Tilt & Reach if Applicable)
9. <input type="checkbox"/>	Lift Chains _____
10. <input type="checkbox"/>	Nameplate _____
11. <input type="checkbox"/>	Battery Retainer Plate _____ (Attachment if Applicable) _____

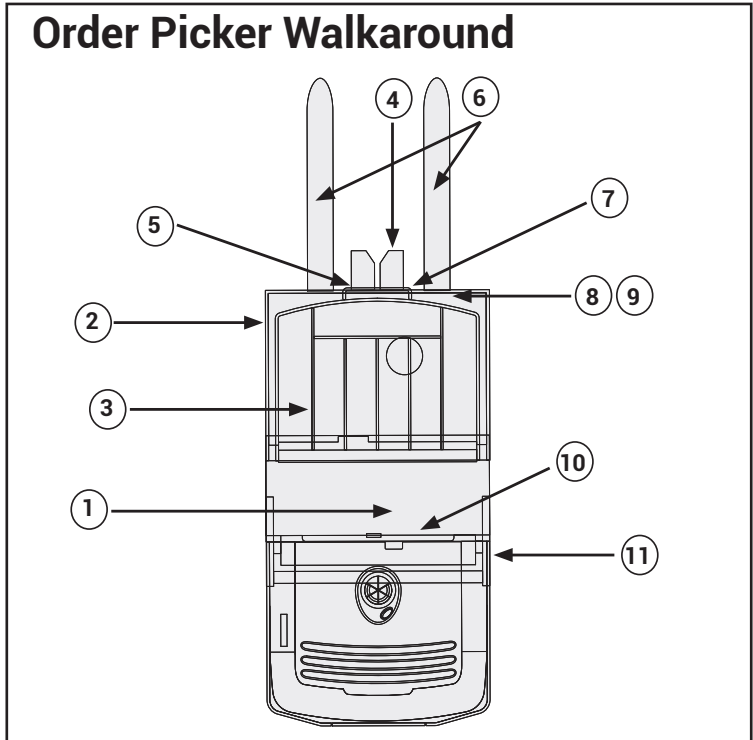

Operational Inspection	
NO	COMMENTS
A. <input type="checkbox"/>	Listen for Unusual Noise _____ Noise _____
B. <input type="checkbox"/>	Check Parking Brake _____
C. <input type="checkbox"/>	Lifting Control _____
D. <input type="checkbox"/>	Tilt Control _____
E. <input type="checkbox"/>	Forward Driving _____ Steering _____ Braking _____
F. <input type="checkbox"/>	Reverse Driving _____ Steering _____ Braking _____ Back-Up Alarm (optional) _____
G. <input type="checkbox"/>	Lights _____
H. <input type="checkbox"/>	Horn _____
I. <input type="checkbox"/>	Gauges _____
J. <input type="checkbox"/>	Oil Spots on Floor _____

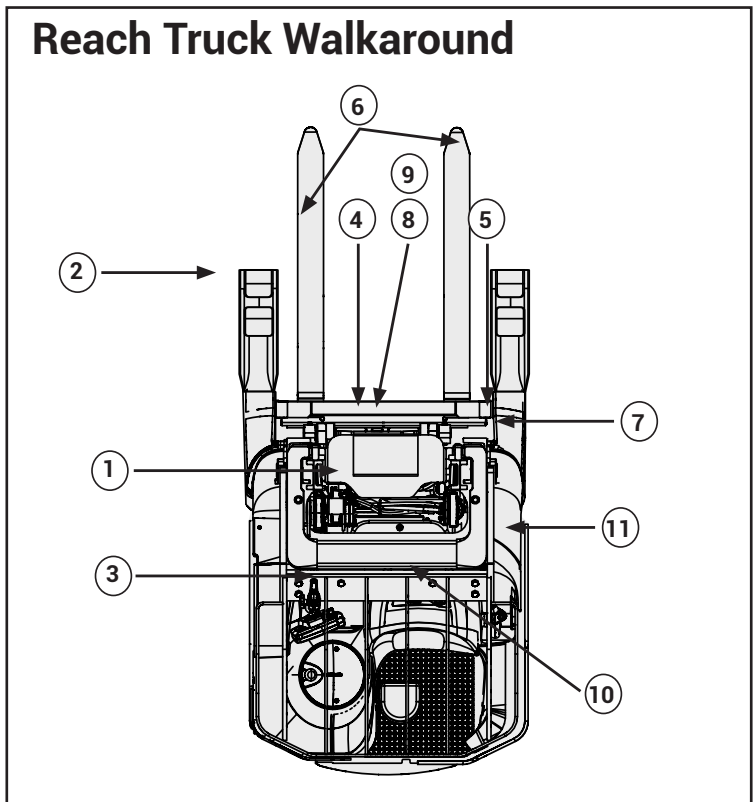

CAUTION: This is not a complete list of all items which may require attention. Operators are responsible for ensuring that the lift truck is in proper working condition in accordance with manufacturer's specifications.

DO NOT OPERATE a lift truck if a problem is detected. Remove the keys, tag "Out of Operation," and report immediately.

SIGNATURE: _____