



**HC FORKLIFT AMERICA CORPORATION**

**Company Address:**  
1338 Hundred Oaks Drive, Suite DD  
Charlotte, NC 28217

**Toll Free:** (888) 652-8395  
**Phone:** (980) 888-8335  
**Fax:** (980) 888-8336

[america@hcforklift.com](mailto:america@hcforklift.com)  
[www.hcforkliftamerica.com](http://www.hcforkliftamerica.com)



2023 VERSION 1/COPYRIGHT 2023

HANGCHA GROUP CO., LTD. reserves the right to make any changes without notice concerning colors, equipment, or specifications detailed in this brochure, or to discontinue individual models. The colors of trucks, delivered may differ slightly from those in brochures.

# A Series Lithium-ion Mini Stock Picker

with capacity of 470lb

**HANGCHA** Lithium-ion  
Re-imagining **POWER**



*Making Material Handling Easier*  
SINCE 1956





# A SERIES MINI STOCK PICKER

The new lithium-ion powered A Series Mini Stock Picker is designed to allow users to finally ditch their rolling ladders in retail environments and quickly pick stock in small warehouses. It is powered by Hangcha's Lithium Iron Phosphate technology and features a maintenance-free battery pack. The mini stock picker is designed around a small footprint and can safely lifting operators up to 118". Its ergonomic design allows operators to comfortably pick and transport goods in narrow, low environments such as small warehouses, supermarkets, and laboratories.



SMALL WAREHOUSE



SUPERMARKETS



LABORATORIES

## Reliability

- / The A Series Mini Stock Picker is designed around a high-strength steel frame to ensure its reliability.
- / The wires and cables are routed so that they are protected when the mini stock picker is being used. This increases the reliability of the electrical system.
- / Switches, connectors, instruments, and other key parts are sourced from industry known suppliers to ensure reliability, performance, and ease of service.

## High Performance

- / The A Series Mini Stock Picker uses a green, environmentally friendly, and efficient Lithium Iron Phosphate battery.
- / An integrated charger enables quick and easy charging.
- / The load tray and platform tray can be lifted manually or electronically. This enables higher picking and transportation efficiency.
- / The maintenance-free, brushless AC walking motor has excellent acceleration performance and low heat generation.
- / The mini stock picker uses a CANBUS structure so that communication between components is faster and more reliable.



The advanced AC control system ensures accurate and stable control of the A Series Mini Stock Picker.





**SIMPLE  
SMART  
SOLID**



## Comfort

- / Lifting & lowering of the mast are buffered to improve comfort.
- / Operator fatigue is reduced thanks to the thick pedal and door pads.
- / The multi-function instrument display includes functions such as mode selection and wheel position. The instrument display also clearly shows various information about the stock picker.
- / The mini stock picker features an optional tray that can be lifted electrically.



Left and Right Hand Operator Sensors



Front and Rear Flashing Lights



## Safety

- / The left and right hand sensors and the safety pedals feature sensors to ensure the operator is in the correct operating position.
- / The Mini Stock Picker features a tilt switch sensor and a door guardrail sensing switch to increase operational safety.
- / The driving speed directly correlates with lifting height to ensure safe operation. This means that the higher the lifting height, the lower the driving speed and the slower the mini stock picker accelerates.
- / The controller offers limits the stock picker's speed when cornering to ensure smooth and safe operation.
- / The Mini Stock Picker features a manual emergency descending function that can be engaged at the rear of the stock picker to lower the platform.
- / When operating the mini stock picker, the front and rear flashing lights alert surrounding personnel and help reduce workplace accidents.

## CATL Lithium Iron Phosphate Battery Packs

- / Integrated Battery Management System (BMS) continually monitors energy management and ensures reliable operation.
- / HANGCHA provides these Lithium Iron Phosphate (LiFePO<sub>4</sub>) battery packs with up to a 5 year or 10,000 hour warranty.
- / See warranty certificate for specific warranty information on the Lithium Iron Phosphate battery packs.

Standard Battery Capacity	
Battery Capacity (V/Ah) (kW·h)	24V/125Ah 3.00kW·h
Charger	Built-in (24V/30Ah)

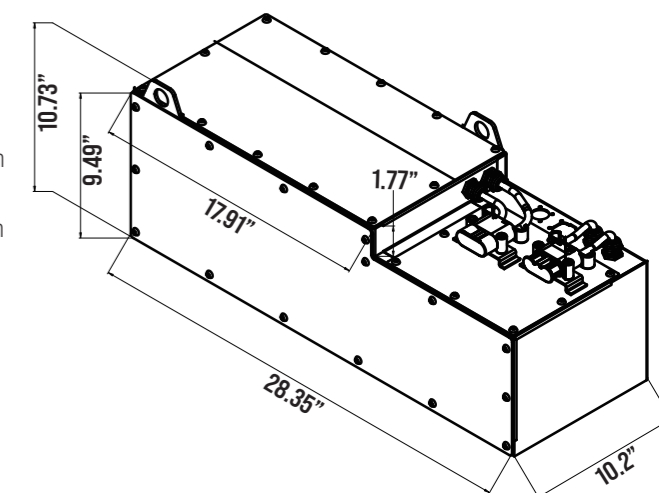



## Maintenance

- / The maintenance-free brushless AC motor and maintenance-free lithium-ion battery significantly reduce operating costs and downtime.
- / The integrated battery display, timer, and fault self-diagnosis gauge allow operators to see the stock picker's current status and facilitate maintenance as needed.
- / All of the stock picker's components are placed at the front of the frame. By simply opening the hood, repairs to be done quickly and easily, thanks to this design.



The lower operation panel is designed to enable the operation of the Mini Stock Picker, such as lifting and lowering the platform and releasing the brake, to be performed outside the vehicle. This is designed to facilitate easy maintenance of the stock picker.

## Options

- / Blue Light
- / Warning Light
- / Front Working Light
- / Side Roller
- / Load Tray
- / Back Cushion



## A Series Storage Assist Vehicle Specification

Distinguishing Marks	1.1	Manufacturer		HANGCHA GROUP CO.,LTD.
		HCFA Model Number		OMP02Li
	1.2	Model		CJD02-AMC1-M11
1.5		Rated Capacity on Load Tray	Q1 lb(kg)	220 (100)
		Rated Capacity on Load Deck	Q2 lb(kg)	250 (115)
		Rated Capacity on Standing Platform	Q3 lb(kg)	300 (135)
1.9	Wheelbase	y in(mm)		40.4 (1026)
Weight	2.1	Service Weight	lb(kg)	1322 (600)
Tires & Chassis	3.1	Tires: solid rubber, superelastic, pneumatic, polyurethane		Polyurethane
	3.2	Tire Size, front	in(mm)	Ø8.3×3.3 (Ø210×83)
	3.3	Tire Size, rear	in(mm)	Ø11×2.4 (Ø280×60)
	3.5	Wheels, number driving, caster/loading (x=drive wheels)		1x, /2
Dimensions	4.2	Height, mast lowered	h1 in(mm)	55.7 (1414)
	4.4	Lift	h3 in(mm)	118 (2995)
	4.5	Height, mast extended	h4 in(mm)	173.6 (4409)
	4.8	Seat Height/standing height	h7 in(mm)	11.8 (300)
	4.19	Overall Length	l1 in(mm)	60 (1525)
	4.21	Overall Width	b1/b2 in(mm)	29.5/29.5 (750/750)
4.31	Ground Clearance, centre of wheelbase	m2 in(mm)	1.6 (40)	
4.35	Turning Radius	Wa in(mm)	47.6 (1210)	
Performance Data	5.1	Travel Speed, laden/unladen	mph (km/h)	5/5 (8/8)
	5.2	Lift Speed, laden/unladen	ft/s (mm/s)	51.2/59 (260/300)
	5.3	Lowering Speed, laden/unladen	ft/s (mm/s)	49.3/49.3 (250/250)
	5.7	Gradeability, laden/unladen	%	5
	5.10	Service Brake		Electromagnetic
Electric Motor	6.1	Drive Motor Rating S2 60 min	hp/kw	0.87 (0.65)
	6.2	Lift Motor Rating at S3 15 %	hp/kw	3 (2.2)
	6.4	Battery Voltage/Nominal Capacity K3, Maintenance free	V/Ah	24/125
		Type of Battery		Lithium
Additional Data	10.7	Sound Pressure Level at the Driver's Seat	dB(A)	68

